

# TAYLOR<sup>®</sup>

## POWER SYSTEMS

Model: **TM20**

Ratings Range:

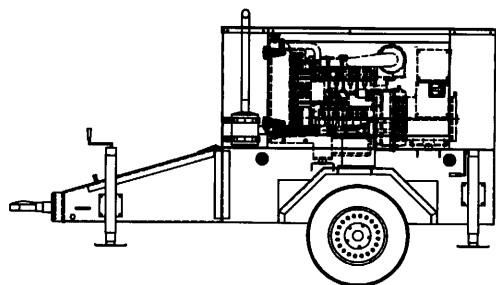

### Features

- Single source responsibility for the generator set and accessories.
- Prototype and production tested to insure one step load acceptance per NFPA 110.
- Two year limited warranty on generator sets and accessories.
- Unit conforms to CSA, NEMA, EGSA, ANSI and other standards.
- Analog control system with an ECU-9988 providing metering and monitoring.
- Heavy duty 4 cycle industrial engine for reliability and fuel efficiency.
- Brushless rotating field generator with class H insulation.
- Integral vibration isolators
- EPA Tier 2 certified engine
- Trailer with integral fuel tank and storage trunk
- Full Output Circuit Breaker

		50Hz	60Hz
Standby:	kw	16	20
	kva	20	25
Prime:	kw	14	18
	kva	17.5	22.5

Generator	Voltage	PH	Hz	125°C Rise		105°C Rise	
				Standby kW/kVA	Rating Amps	Prime kW/kVA	Rating Amps
BCI184E311	277/480	3	60	20/25	30	18/22.5	27
	139/240	3	60	20/25	60	18/22.5	54
	254/440	3	60	20/25	33	18/22.5	30
	127/220	3	60	20/25	66	18/22.5	59
	240/416	3	60	20/25	35	18/22.5	31
	120/208	3	60	20/25	69	18/22.5	62
	120/240	3	60	20/25	60	18/22.5	54
	219/380	3	60	20/25	42	18/22.5	34
	120/240	1	60	18/18	75	16/16	67
	254/440	3	50	16/20	26	14/17.5	23
	127/220	3	50	16/20	52	14/17.5	46
	120/208	3	50	16/20	56	14/17.5	49
	240/415	3	50	16/20	28	14/17.5	24
	219/380	3	50	16/20	30	14/17.5	27
110/190	3	50	16/20	61	14/17.5	52	
110/220	1	50	15/15	68	13/13	59	
BCI184E06	120/240	1	60	20/20	83	18/18	75
DUAL VOLTAGE	277/480	3	60	20/25	30		
	120/208	3	60	20/25	69		

RATINGS: All three-phase units are rated at 0.8 power factor. All single-phase units are rated at 1.0 power factor.

STANDBY RATINGS: Standby ratings apply to installations served by a reliable utility source. The standby rating is applicable to varying loads for the duration of a power outage. There is no overload capability for this rating. Ratings are in accordance with ISO-3046/1, BS 5514, AS 2789, and DIN 6271.

PRIME POWER RATINGS: Prime power ratings apply to installations where utility power is unavailable or unreliable. At varying load the number of generator set operating hours is unlimited. A 10% overload capacity is available for one hour in twelve. Ratings in accordance with ISO-8528/1, overload power in accordance with ISO-3046/1, BS5514, AS2789, and DIN 6271. For limited running time and base load ratings consult the factory. The generator set manufacturer reserves the right to change the design or specifications without notice and without any obligation or liability whatsoever.

GENERAL GUIDELINES FOR DERATION: Altitude: Derate 0.5% per 100m (328 ft.) elevation above 1000m (3279 ft.)  
Temperature: Derate 1.0% per 10°C (18°F) temperature above 40°C (104°F).

# APPLICATION & ENGINEERING DATA

## ENGINE

Engine Specifications	60 Hz	50 Hz
Manufacturer	Perkins	
Engine, model, type	404C-22G	
Cylinder arrangement	IN-LINE 4 CYLINDER	
Displacement, cu. in. (L)	135 (2.26)	
Bore and stroke, in. (mm)	3.3 (84) x 3.9 (100)	
Compression ratio	23.3:1	
Piston speed, ft./sec. (m/sec)	19.5 (5.94)	16.25 (4.95)
Rated rpm	1800	1500
Max. power at rated rpm, hp (kw)	32.6 (24.3)	27.6 (20.6)
Cylinder head material	Cast iron	
Crankshaft material	Forged steel	
Governor type	Mechanical	
Frequency regulation, no load to full load	3-5%	
Frequency regulation, steady state	±0.8%	
Air cleaner type, all models	Dry paper element	
Combustion air, cfm (m <sup>3</sup> /min.)	61.4 (1.74)	51.2 (1.45)

## EXHAUST

Exhaust System	60 Hz	50 Hz
Exhaust flow at rated kW, cfm (m <sup>3</sup> /min.)	168 (4.76)	139 (3.94)
Exhaust temperature at rated kW, dry exhaust, °F (°C)	950 (510)	941 (505)
Maximum allowable back pressure, in. Hg (kPa)	3.012 (10.2)	
Exhaust outlet size at hookup, in. (mm)	1.68" (42.7)	

## ENGINE ELECTRICAL

Engine Electrical System	60 Hz	50 Hz
Battery charging alternator:		
Ground (negative/positive).....		Negative
Volts (DC).....		12
Ampere rating.....		55
Starter motor rated voltage (DC)		12
Recommended battery cold cranking amps (CCA) rating for 0°F (-18°C)		740
Quantity of batteries		1
Battery voltage (DC)		12

## FUEL

Fuel System	60 Hz	50 Hz
Fuel supply line, min. ID, in. (mm)	5/16 (7.93)	
Fuel return line, min. ID, in. (mm)	.125 (3)	
Max. lift, engine-driven fuel pump, ft.	2.6	
Fuel prime pump	manual	
Fuel filter	CANISTER	
Recommended fuel	#2 diesel	

## FUEL CONSUMPTION

Fuel Consumption	60 Hz	50 Hz
<b>Diesel, gph (Lph) at % of load</b>		
100%	1.93 (7.3)	1.64 (6.2)
75%	1.27 (4.8)	1.06 (4.0)
50%	.92 (3.5)	.77 (2.9)

## COOLING

Cooling System	60 Hz	50 Hz
Ambient temperature °F (°C)	115 (46)	
Radiator system capacity, including engine, gal. (L)	1.84 (6.98)	
Engine jacket water flow, gpm (Lpm)	12.8 (48.5)	10.6 (40.3)
Heat rejected to cooling water at rated kW, dry exhaust Btu/min.	1265	1114
Water pump type	centrifugal	
Fan diameter, including blades, in. (mm)	15.35 (390)	
Fan hp (kW)	0.5 (0.4)	.4 (.3)
Max. restriction of cooling air, intake and discharge side of rad., in. LBF in <sup>2</sup> (kPa)	5.0 (35)	
Radiator-cooled cooling air, cfm	1400	1200

## LUBRICATION

Lubricating System	60 Hz	50 Hz
Type	Full Pressure	
Oil pan capacity with filter, qts. (L)	11.2 (10.6)	
Oil filter, quantity, type	1 spin on	
Oil cooler	none	

## ANALOG CONTROL PANEL

- Taylor Power Systems Analog Auto Start Control Panel. The panel is equipped with AC Voltmeter, AC Frequency Meter, Percent of Load Meter, Running Time Meter, Control Toggle Switch with Off/Auto/Manual positions, and ECU-9988 engine control with specific safety shutdown lights.
- Oil Pressure Gauge, Water Temperature Gauge, Battery Voltmeter, Fuel Level Gauge, and Hourmeter

## ECU-9988 FEATURES

- Engine Started LED
- Overspeed Shutdown LED
- Overcrank Shutdown LED
- High Water Temperature Shutdown LED
- Low Oil Pressure Shutdown LED

The ECU automatically cranks, starts, and monitors the engine for Overcrank, Overspeed, High Water Temperature, and Low Oil Pressure. A built in speed switch uses a magnetic pickup to monitor engine speed for crank disconnect and overspeed. The bypass timer/logic assures Low Oil Pressure and High Water Temperature override during the crank period and an additional adjustable period after crank disconnect. The ECU monitors the Magnetic Pickup signal for problems during both cranking and running. If a problem is detected the engine will shutdown and Overcrank and Overspeed LED's will both turn on.

# GENERATOR SPECIFICATIONS

---

## STANDARDS

BC16 and BC18 industrial generators meet the requirements of BS5000 PART 3, VDE0530, UTE5100, NEMA MG1-22, CEMA, IEC34-1, CSA22.2 AND AS1359.

## EXCITATION SYSTEMS

### **SX460 & SA465 AVRs**

The SX460 AVR is available for use with both BC16 and BC18 generators. The SA465 AVR is available for use with the BC18 generator only.

With these self-excited systems the main stator provides power via the automatic voltage regulator (AVR) to the exciter stator. The high efficiency semiconductors of the (AVR) ensure positive build up from initial low levels of residual voltage.

The exciter rotor output is fed to the main rotor through a three phase full wave bridge rectifier. The rectifier is protected by a surge suppressor against surges caused, for example, by short circuit or out of phase paralleling.

The SA465 will support a range of electronic accessories, including a 'droop' Current Transformer (CT) to permit parallel operation with other ac generators.

## VOLTAGE REGULATION

Self excited AVRs are 2 phase average voltage sensed and will control the generator output voltage to within the following limits:

SX460  $\pm 1.5\%$

SA465  $\pm 1.0\%$

from no load to full load including cold to hot variations for any power factor between 0.8 lagging and unity allowing for a 4% engine speed variation. Voltage is adjusted using a trimmer on the AVR.

## INSULATION / IMPREGNATION

The insulation system is Class 'H'.

All wound components are impregnated with materials and processes designed specifically to provide protection against the harsh environments encountered in generator applications. Varnishes and resins are selected and developed to provide the high build required for static windings and the high mechanical strength required for rotating components.

## WINDINGS & ELECTRICAL PERFORMANCE

All generator stators are wound to 2/3 pitch. This eliminates triplen (3rd, 9th, 15th...) harmonics on the voltage waveform and is found to be the optimum design for trouble-free supply of non linear loads. The 2/3 pitch design avoids excessive neutral currents, sometimes seen with higher winding pitches, when in parallel with the mains.

A fully connected damper winding reduces oscillations during paralleling. This winding, with 2/3 pitch and carefully selected pole and tooth designs, ensures very low waveform distortion.

## TELEPHONE INTERFERENCE

THF (as defined by BS4999 Part 40) is better than 2%. TIF (as defined by ASA C50.12) is better than 50.

## RADIO INTERFERENCE

The absence of brushgear and the high quality AVR ensure low levels of interference with radio transmissions.

Additional RFI suppression may be supplied if required.

## ENCLOSURE

IP22 (NEMA 1) is standard for all industrial generators. Giving drip proof protection of 60 degrees from vertical.

Inlet air filters are available as an option on all generators, at reduced ratings (5% derate).

## SHAFT

All generator rotors are dynamically balanced to better than BS6861: Part 1 Grade 2.5 for minimum vibration in operation.

## QUALITY ASSURANCE

Generators are manufactured using production procedures having a quality assurance level to BS EN (ISO9001).

# STANDARD FEATURES AND ACCESSORIES

## Standard Features

- Trailer with integral fuel tank
- Weather enclosure
- Vibration isolators
- Oil drain valve with extension
- Battery
- Battery rack
- Battery cables
- Exhaust silencer
- Flex exhaust connector
- Analog Control Panel
- Owners manual
- Flexible fuel lines
- Glowplug cold weather starting aid
- Line circuit breaker
- (2) 15 amp GFI duplex receptacles
- (2) 30 amp twist lock receptacles

## Optional Accessories

- Sound attenuated enclosure
- Block Heater
- Battery charger
- Output Power Cable
- Multi-voltage selector switch
- Dual Voltage Generator

## Detailed Description of Trailer

Trailer equipped with single 3500 pound axle, integral DOT rated 75 gallon fuel tank, electric brakes with safety disconnect and 7 wire connector, torsion axle, front tongue jack, two rear stabilizer jacks, ICC lighting, and license plate bracket. These trailers also come with a lockable storage trunk at front of trailer and cable storage in the rear.

### WEIGHTS AND DIMENSIONS

TM20

Overall Size Standard Unit,  
L x W x H, in.: (125" x 72" x 69")

Overall Size Sound Attenuated Unit,  
L x W x H, in.: (125" x 72" x 69")

Standard unit dry weight: 2518 pounds

Sound attenuated unit dry weight: 2550 pounds

GVWR: 3500 pounds

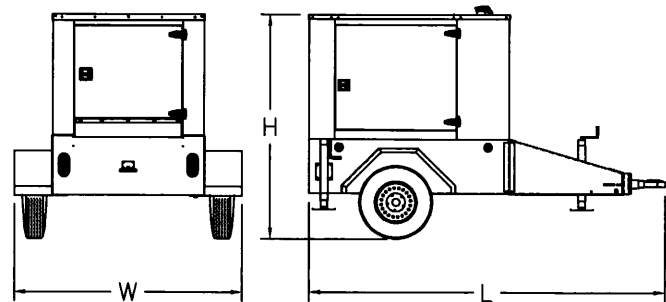

Note: This drawing is provided for reference only and should not be used for planning installation. Contact your local distributor for more detailed information.

## DISTRIBUTED BY:

# TAYLOR

## POWER SYSTEMS

461 Hwy. 49S  
Richland, Mississippi 39218  
Phone (601)-932-5674  
Toll Free 1-800-367-7639  
FAX (601)-932-4028  
Web Site [www.taylorpower.com](http://www.taylorpower.com)